



**INSTITUTION OF RAILWAY SIGNAL ENGINEERS  
MINOR RAILWAYS SECTION  
GUIDELINE ON**

**TRAIN DETECTION  
BONDING AND CABLES**

Record of Amendments		
Issue	Date	Amendments
1.0	March 2013	Original Issue

Anyone who wishes to contribute additional items or correct / amend any of the entries or wants further information may contact the IRSE Minor Railways Section Guideline co-ordinator at [mrsdc@irse.org](mailto:mrsdc@irse.org) or via the IRSE Headquarters.

Any railway seeking to follow the guidelines in this document should ensure that it is suitable for their particular railway concern. Duty holders are reminded that they must be satisfied that they are doing all that is needed under health and safety duties to control risks. Compliance with this guideline issued by the IRSE is not mandatory as it provides advice on how an issue may be addressed.

## TABLE OF CONTENTS

<b>1</b>	<b>INTRODUCTION</b> .....	<b>4</b>
<b>2</b>	<b>DEFINITIONS</b> .....	<b>4</b>
<b>3</b>	<b>SAFETY CONSIDERATIONS</b> .....	<b>6</b>
3.1	Before Starting Work .....	6
3.2	Risk Assessments .....	6
3.3	Electric Shock Risk.....	6
<b>4</b>	<b>BASIC REQUIREMENTS</b> .....	<b>6</b>
4.1	General.....	6
4.2	Operation of a Basic Track Circuit.....	6
<b>5</b>	<b>CABLES AND RAIL TERMINATIONS</b> .....	<b>7</b>
5.1	General.....	7
5.2	Cables .....	7
5.3	Rail Terminations.....	7
5.4	Rail Drilling .....	8
5.5	Cable Connections .....	8
<b>6</b>	<b>BONDING</b> .....	<b>11</b>
6.1	Rail Joint Bonds.....	11
6.2	Bonding of Points and Crossings .....	12
6.3	Jumper Cables .....	12
<b>7</b>	<b>TRACK CIRCUIT INTERRUPTERS</b> .....	<b>13</b>
<b>8</b>	<b>TRACK CIRCUIT DESIGN</b> .....	<b>14</b>
8.1	General.....	14
8.2	Plain Line.....	14
8.3	Points and Crossings.....	15
<b>9</b>	<b>MAINTENANCE REQUIREMENTS</b> .....	<b>16</b>
9.1	Before Starting Work .....	16
9.2	Details.....	16
9.3	Visual Examination .....	16
9.4	Maintenance Standards.....	16
9.5	Maintenance Intervals .....	16
9.6	Maintenance Records.....	17
<b>10</b>	<b>REFERENCES</b> .....	<b>17</b>
<b>11</b>	<b>APPENDICES</b> .....	<b>17</b>

## TABLE OF FIGURES

Figure 1 - Basic Track Circuit .....	6
Figure 2 - Cable Terminations .....	7
Figure 3 – M6 Taper Pin .....	8
Figure 4 - Cable Secured in Orange Pipe.....	8
Figure 5 - Cable with preformed rail connection .....	9
Figure 6 - "L" Plate Connector .....	9
Figure 7 - Termination 50/0.25mm Cable to an "L" Plate .....	10
Figure 8 - "D Link" termination.....	10
Figure 9 - Channel Pin .....	11
Figure 10 - Rail Joint Bond .....	11
Figure 11 - Switch to Stock Rail Bonding .....	12
Figure 12 - Fabricated Crossing .....	12
Figure 13 - Examples of Jumper Cable Identification .....	13
Figure 14 - Track Circuit Interrupter.....	14
Figure 15 - Typical Plain Line Track Circuits .....	15
Figure 16 - Typical Bonding for a Single Point .....	15
Figure 17 - Typical Bonding for a Crossover .....	16

## 1 INTRODUCTION

This document provides information on track circuit bonding for non-electrified lines. It includes information on cables, cable terminations and track circuit interrupters.

This document does not include details about any form of train detection such as track circuits, axle counters, treadles or position detectors.

It is not intended to be a definitive document on how to design, install, test and maintain DC track circuits, but to disseminate information on best practice.

The IRSE Minor Railways Section has used its best endeavours to ensure that the contents of this document are factually and technically correct and is suitable for its stated purpose but the IRSE Minor Railways Section cannot be liable for any subsequent use to which the document may be put.

## 2 DEFINITIONS

The following is a list of the more common definitions, a fuller description may be found in subsequent sections.

In this document terms relating to gender equally apply to the opposite.

Any reference made to "Signal Engineer" is a generic term and can relate to;

- Maintenance – person in charge of Signal Engineering for the Railway
- Design – Responsible Design Engineer for the design authority
- Installation – Person in charge of Installation
- New Works Testing – Tester in Charge

Any reference made to "Signalman" is a generic term and applies to the person in charge of regulating trains on the section of line where work is required.

Any reference made to "Railway" is a generic term and applies to the owner and/or operator of the relevant infrastructure.

**Track Circuit** A means of proving the absence of a train on a section of track. The two rails are used to connect a power source to a detector (usually a relay). The normal state with no train present is that the detector is energised. When a train occupies the section of track, the wheels short-circuit the two rails together, which causes the current to by-pass the detector, which therefore de-energises (i.e. drops away).

**Polarity** "B" is the positive side.  
"N" is the negative side.  
Note: The polarity of the voltage on the rails can be made to change within the length of the track circuit by using insulated rail joints and jumper cables.

**Feed End** The end of the track circuit where power is fed into the rails. On diagrams, the feed end rail connections may be designated "TN" or "TB" according to the polarity.

**Relay End** The end of the track circuit where the relay is connected to the rails (even if the relay is connected to the rails through an intermediate device). On diagrams, the relay end rail connections may be designated "RN" or "RB" according to the polarity.

**Insulated Rail Joint (IRJ)** A joint between two lengths of rail, designed to isolate electrically one length of rail from another. The shape and construction of the IRJ varies according to the type of rail each side of it. The traditional joint is bolted to the rails by using an insulated fishplate.

This joint is also known as an Insulated Block Joint (IBJ).

They are used to:

1. limit how far a track circuit extends.
2. allow a changeover in rail polarity within a track circuit.
3. divide up lengths of rail so that they can be connected together in a manner to make train detection more effective.

Staggered Polarities	Track circuits are designed so that the polarity of the voltage on the rail on one side of an IRJ is the opposite of that on the other side. This is done so that if an insulated joint fails, the two polarities will oppose each other and cancel each other out. The resulting reduced voltage will cause the track relay to drop. This is safer than allowing the track relay to become energised from a supply from which it should be insulated.
Fouling Point	The position on a converging, diverging or crossing line beyond which the encroachment of any part of a vehicle would infringe the required passing clearance for a vehicle on the other line.
Transposition IRJs	IRJs within a track circuit specially put to permit a changeover of polarities. This may be necessary to create staggered polarities at the IRJs between two neighbouring track circuits, or they may be used to extend the track circuit through point and crossing rails.
Staggered IRJs	Two IRJs in a pair of rails that are not exactly opposite each other. The length of maximum stagger must not exceed the requirements of the Railway.
Bonds	Where sections of rail are bolted together with fishplates, the electrical continuity between them may not be adequate. To ensure there is a good electrical connection, lengths of wire or cable known as bonds are connected from one rail to the other.
Jumpers	Lengths of cable connecting together rails which are separate or deliberately insulated from each other. Usually, this is so that the rails are connected in series within the same track circuit through points and crossings.
Ballast Resistance	Each rail has a leakage to other rails and to earth through the sleepers and the ballast. The leakage resistance, effectively connected across the rails (and hence across the track circuit) is termed ballast resistance. It may be given as a value of ohms for the whole of a track circuit or as ohms/unit length for a given length of track.
Drop Shunt	The highest value of resistance which, when connected across the track circuit as a test, will cause the track relay to fully drop away from its energised position. The exact position of the resistance and how far the relay has to drop will be defined in the test conditions for the track circuit.
Prevent Shunt	The highest value of resistance which, when connected across the track circuit as a test, will prevent the track relay from picking up from its fully de-energised position. The exact position of the resistance will be defined in the test conditions for the track circuit.
Pick-Up Shunt	The lowest value of resistance which, when connected across the track circuit as a test, will cause the track relay to pick up from its de-energised position. The exact position of the resistance and how far the relay has to pick will be defined in the test conditions for the track circuit. In reality, the Prevent Shunt and the Pick-Up Shunt values will be very nearly the same.
Shunt Box	A device that is placed across the track to simulate the presence of a train. It is used to provide readings for the drop shunt, prevent shunt and pick-up shunt testing. It consists of a variable resistor and two wires which are clipped to the rail connections.
Cut Section	A method of reducing the continuous length of a track circuit by the use of shorter individual track circuits, each one controlling the same final TPR. They are normally indicated as a single track circuit on the signalman's indication.
Single Rail	A track circuit where only one of its rails is insulated by IRJs from the adjacent track circuits.
Double Rail	A track circuit where both rails are insulated by IRJs from the adjacent track circuits.
Common Rail	On a single rail track circuit, the rail without the IRJs, or the rail wired in parallel through points and crossings.
TR	Track Relay. The relay that is connected across the rails.

TPR	Track Repeating Relay. The relay used within the signal box or interlocking that is controlled by the operation of the TR(s).
TSS	Track Service Set. A track circuit feed unit that also charges a standby battery, which is used when there is a failure of the main power supply.

### 3 SAFETY CONSIDERATIONS

#### 3.1 Before Starting Work

Before working on any track circuit, inform the signaller and come to an understanding as to the work to be done. Any work which involves disconnecting a track circuit may lock signals and points and prevent train movements.

#### 3.2 Risk Assessments

When proposing to install a new track circuit, consideration should be given to what type should be used in relation to limits of operation (track circuit length, type of rolling stock etc.), track layout (points, level crossings etc.), restrictions on available power supply and other local conditions (more than normal wet ballast).

#### 3.3 Electric Shock Risk

Most track circuits are low voltage; however it should be established what type of track circuit and any potential electric shock risk before commencing work.

### 4 BASIC REQUIREMENTS

#### 4.1 General

The bonding of any track circuit, regardless of the type of track circuit used, must ensure that, as far as practical, the train will be continuously detected within the overall parameters of the track circuit. This will be achieved by ensuring that, as far as practical, all rails are bonded in series within the track circuit (see section 8.1).

A track circuit should also be designed to ensure that, as far as practical, any disconnection of a cable or other bonding will cause the track circuit to show occupied.

#### 4.2 Operation of a Basic Track Circuit

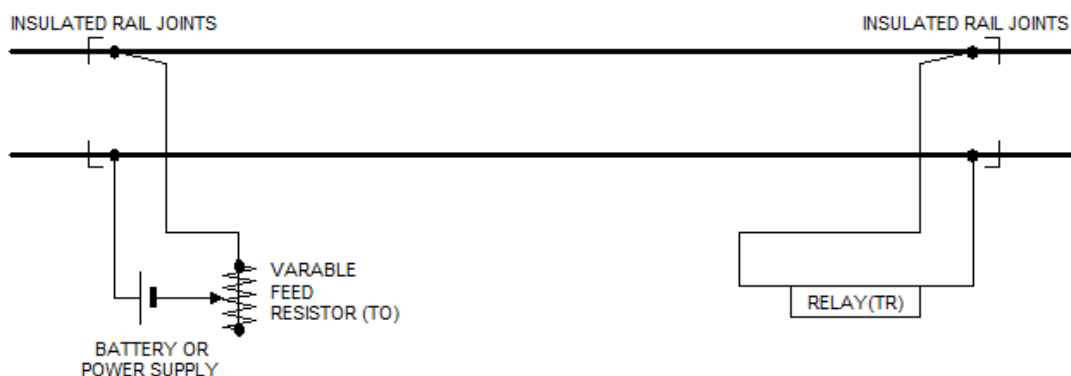

Figure 1 - Basic Track Circuit

A feed is applied to the rails at one end, with each rail being of opposite polarity. At the other end a relay is connected across the rails. The current passes down one rail to energise the relay and returns through the other rail. When clear of all vehicles, the track relay (TR) is energised. When a vehicle wheelset is placed across the rails, it causes a short circuit across the feed which drops the TR.

To ensure correct operation, the feed end voltage is regulated, usually by a variable resistor that is wired in series with the feed. This resistor also acts as a load to the feed when the track has a short circuit from the wheelset.

It is safer to use a circuit that is normally energised as, under a fault condition such as a loss of power, the relay will drop and indicate "occupied" to the signalman. If a track circuit relied on a relay to pick, a power failure would not operate the circuit and a train would not be detected.

The basic track circuit uses DC voltage; however, other types of track circuit using AC voltages at various frequencies have also been developed. Unless stated otherwise, the information contained within this document is applicable to all types of track circuit.

The type of track circuit used will be decided at the design stage.

## 5 CABLES AND RAIL TERMINATIONS

### 5.1 General

All cables must be as per the signalling diagrams. If it is required to change the cable type, length or termination arrangement, advice must be obtained from the Signal Engineer.

### 5.2 Cables

The standard track circuit cable is a single core of size 2.5 sq mm, comprising of 50 strands of 0.25 sq mm conductors, insulated with EPR (Ethylene Polypropylene Rubber), and with HDPCP (Heavy Duty PolyChloroprene) outer sheathing. The EPR insulation shall conform with type GP4 properties as shown in BS 7655: Section 1.2. This cable is considered as "best practice" for standard gauge railways.

This cable is sufficiently flexible to be able to be bent down to a radius of about three times its overall diameter if required, but a larger radius is preferred if space permits.

It is possible to use any cable for track circuits, however the following must be considered;

- a) Cable resistance. Most track circuits operate at relatively low voltages and any in-line resistance may affect the correct operation and make it difficult to set up the track circuit correctly.
- b) Environment. Track circuit cables are normally on the ballast at rail level. The cable should be robust enough to ensure that normal use (people walking, ballast movement, oil spills etc.) does not cause any damage to the cable.

### 5.3 Rail Terminations

All cables must be securely terminated to the rails. Where possible, two termination points should be used so that a single disconnection will not cause the track circuit to show occupied. In some circumstances, the feed and relay end cables may be duplicated.

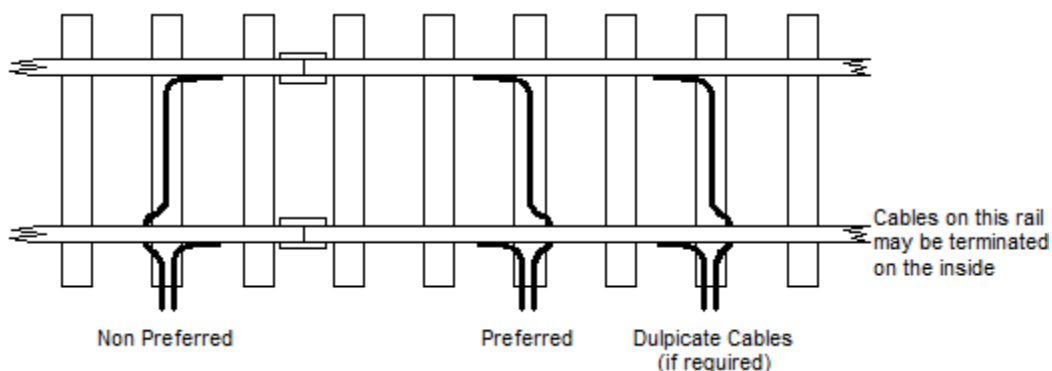

Figure 2 - Cable Terminations

Figures 2 and 4 shows rail cables terminated towards the IRJ. Where possible there should be an empty sleeper bed between the IRJ and the cable termination. This will allow the civil engineer's department to pack the rail joint without damaging the cable. If duplicate cables are to be used, these should be terminated, where possible, two sleeper beds from the first cable.

#### 5.4 Rail Drilling

Only the correct type of rail drilling machine **MUST** be used for drilling holes. A normal hand held drill **MUST NOT** be used, even if it mounted in a stand. Rail drills of all types are considered as an obstruction to the line and must be protected in accordance with the Railway's Rule Book.

Rail drills can be worked by or powered and can be mounted "over the rail" or "under the rail". The hand-operated drill will drill one hole at a time; the second hole must be measured. The easiest way to do this is to use an "L" plate (see section 5.5.2) as a template. The power operated rail drill can drill two holes at a time at the correct distance apart. Before using this machine, staff must acquaint themselves with its operation and safety requirements.

Both types of rail drill are designed to take only one size of drill for drilling rails. **DO NOT** use them for any other purpose.

#### 5.5 Cable Connections

Drill holes in the rails with a  $\frac{9}{32}$ " drill, 3" (76mm) apart. A correct type rail-drilling machine should be used that either clips over or under the rail. When using a machine that is fitted with two drills, the holes are correctly spaced. The holes should be offset from the centre of the sleeper bed towards the IRJ; this will allow the cable to curve into its final position.

Firmly hammer the M6 taper pins into the holes. Do not damage the threads. Fit a washer and nut to each pin and tighten the nuts.



Figure 3 – M6 Taper Pin

Cables placed under the rails should be secured so that so that they cannot move or be damaged when work is carried out on the permanent way. The cables can be secured to the sleepers with suitable clips (see figure 2) or run through a suitable pipe (see figure 4).



Figure 4 - Cable Secured in Orange Pipe



### 5.5.1 Preformed Cables

Where possible, it is preferred to use track circuit cables with a preformed flexible rail connection (two holes, 76mm apart) on one end.

The cable is 50/0.25mm (2.5 sq mm) as described in section 5.2 and can be supplied in various lengths.

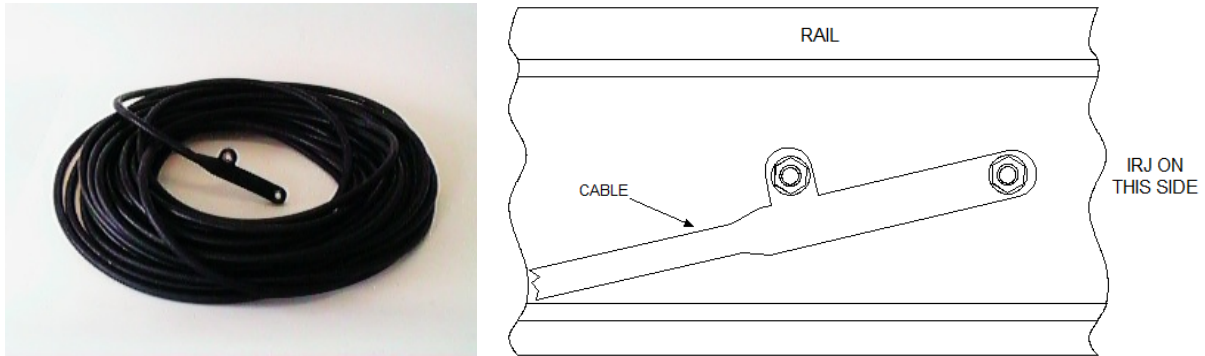

Figure 5 - Cable with preformed rail connection

### 5.5.2 "L" Plate Connector

If preformed cables are not available, this method of connection should be considered. It is designed for use with single core cable of size 50/0.25mm (2.5 sq mm) as described in section 5.2.

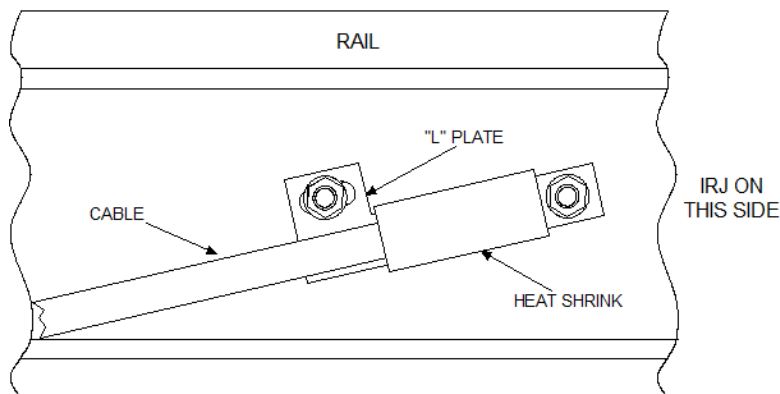

Figure 6 - "L" Plate Connector

#### Method of Assembly

- Strip back the cable as shown in figure 6. Fit the correct size crimp terminal and crimp it firmly.
- Slide the heat shrink sleeve onto the "L" plate and thread the cable through the sleeve.
- Place the whole assembly on to the taper pins and fit the remaining washers and nuts. If self-locking nuts are not used fit a second nut on top. The cable should be run so that it "faces" into the IRJ.
- Move the heat shrink so that it covers the entire stripped length of the cable. Apply heat to the sleeve; the preferred method is to use a hot air blower. If a naked flame is to be used it should be directed at the rail so that the heat is reflected onto the sleeve. A naked flame **MUST NOT** be used directly on the sleeve as it liable to burn and split.
- On flat bottom rails only, fit a flange clip over the cable and push onto the foot of the rail (see figure 4).

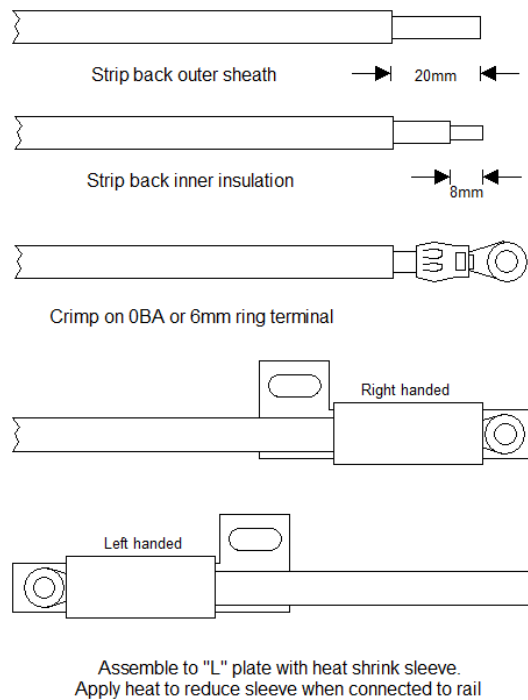

Figure 7 - Termination 50/0.25mm Cable to an "L" Plate

### 5.5.3 Other Cable Terminations

Other methods of cable terminations can be used, particularly with regard to narrow gauge railways using smaller section rail.



Figure 8 - "D Link" termination

Figure 7 shows a termination method which is sometimes known as a "D link". The connector is formed of  $\frac{1}{4}$ " (6.35mm) diameter copper wire, which is pre-formed into a loop at each end. The track circuit cable is stripped of sufficient insulation to enable the bare wire to be soldered to the copper wire.

If this method is required to be used and it is not possible to obtain the correct item, the connector can be formed from half a track circuit bond with the loops formed by wrapping around a round object of suitable diameter.

This method is generally not used for new work but can be found on existing track circuits.

## 6 BONDING

### 6.1 Rail Joint Bonds

To ensure electrical continuity across rail joints within a track circuit, the rails on each side of the joint must be bonded together. Rail joint bonds are  $\frac{1}{4}$ " (6.35mm) diameter and 1670mm long bare galvanised steel wire, secured to the rail by tapered channel pins. Two bonds are fitted across each joint.

Any temporary bonding that is required across rail joints that are later to be welded or removed shall be to the same standard as permanent bonding.

To install the bonds drill two  $\frac{9}{32}$ " holes in the web of the rail, 3" (76mm) apart in the first sleeper bay each side of the joint. When using an approved power drill designed for rail drilling, both holes are drilled at the same time at the correct distance.

**All rail-drilling machines are regarded as an obstruction to the line and must be protected in accordance with the Railway's Rules.**

Bond wire is supplied in lengths which are correct for standard rail joints. Each bond should be fitted between two corresponding holes on each side of the joint (i.e., from nearer hole on one side of the joint to the far hole on the other side); all bonds are thus the same length. The bonds are held in place by a tapered channel pin that is hammered in place.



Figure 9 - Channel Pin

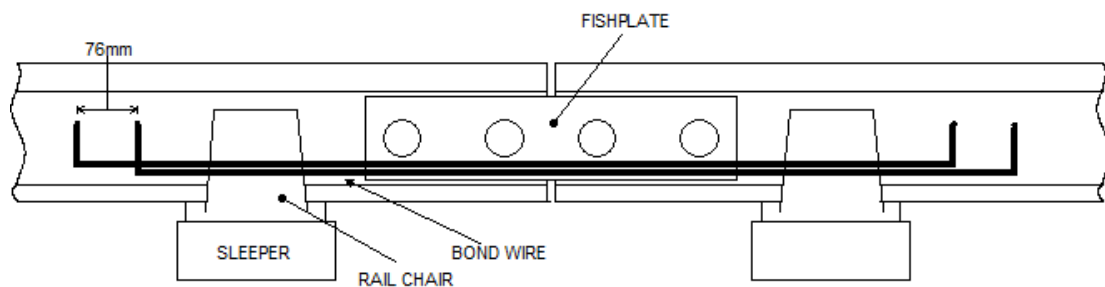

**BONDS TO BE FITTED ON THE INSIDE OF THE RAIL WHERE POSSIBLE**

Figure 10 - Rail Joint Bond

All new bonds should normally be fitted on the inside of the rail, and run close to the base of the rail. They **MUST NOT** be threaded through the fishplates, rail fastenings or under the rails.

In areas that are prone to vandalism, instructions will be issued by the Signal Engineer if an alternative arrangement is required.

Pass one end of the bond wire through the appropriate hole in the rail from the inside with about one inch protruding through on the outside. Insert the tapered end of the channel pin into the hole from the outside, and ensure that the bond wire is lying in the channel of the pin. Hammer the pin into the rail. Check that the pin and the bond are securely held in the rail.

Lay the bond along the rail, bending it gently as required around rail fittings. Pass the other end of the bond through the appropriate hole in the other rail and secure as described above.

## 6.2 Bonding of Points and Crossings

Adjacent rails in points and crossings should be bonded together in a similar manner to bonding of rail joints as described above. Examples are shown below.

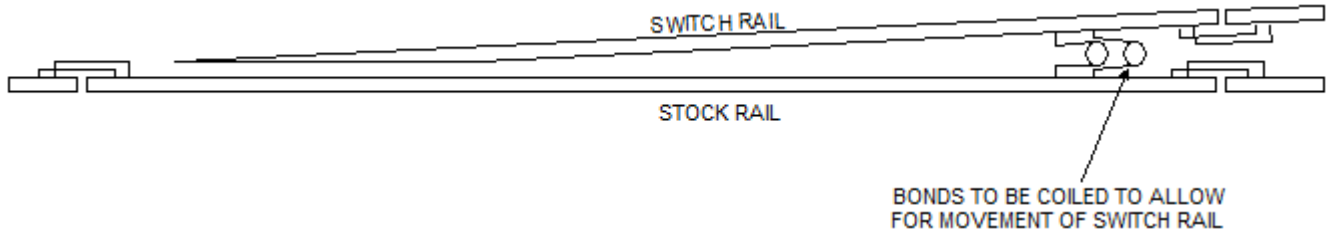
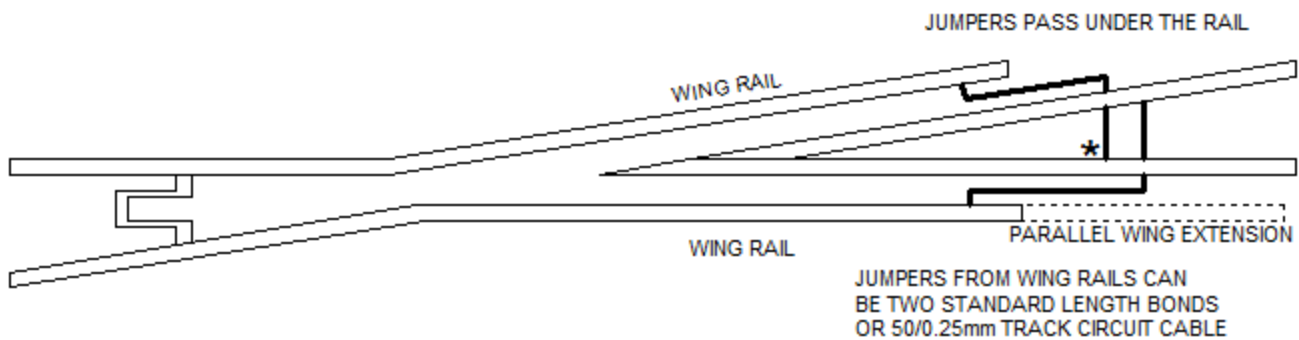

Figure 11 - Switch to Stock Rail Bonding



IF A PARALLEL WING EXTENSION IS FITTED, HOLE MARKED \* TO HAVE JUMPER FITTED PRIOR TO ASSEMBLY OF VEE AND BEFORE WING IS ATTACHED. BONDS OR CABLE TO BE TIED ALONG RAIL TO PREVENT DAMAGE IN TRANSIT.

Figure 12 - Fabricated Crossing

Hardened steel rail is sometimes used for points and crossings; special drills are available for these. Do not attempt to drill a hardened rail with a normal drill.

Where parallel rails that are to be bonded are close together (e.g., switch rail to stock rail bonding), the bond should be cut in half and coiled so that it lies neatly in the gap. Alternatively, for greater flexibility through point fittings, 7 strand galvanised signal wire may be used. This is terminated in the same manner as a rail bond. Where longer than standard bonding is required, it should be done with 50/0.25mm track circuit cable.

All bonds must be well clear of areas where they might be hit by flanges or other parts of passing vehicles.

## 6.3 Jumper Cables

Jumper cables are provided to maintain continuity of track circuits through points, crossings and across polarity changing IRJs. It is important that all sections of track are connected in series; if this is not done, there is a possibility of a wrong side failure in that a train may not be detected if a bond or rail is broken. It is therefore important that all jumper cables are connected to the positions shown on the bonding plan.

When installing jumper cables (either new or replacements) follow the arrangements shown on the IRJ plan. Where possible, jumper cables should be placed in a convenient secure cable route.

Standard jumpers should be of 50/0.25mm track circuit cable. If preformed cables are not used, then the rail connections should be made as shown in section 5.6.1.

Where a jumper has to cross tracks, ensure that it is protected by running it through a pipe or cable route. A non-preferred method is to clip the cable to the sleepers using suitable clips.

Jumper cables may be fitted with a unique identification label. An example could be;

Cable Name AB JB1

where AB is the track circuit name  
 J indicates that is a jumper cable  
 B identifies it as a positive jumper (use N if negative)  
 1 identifies it as the first positive jumper within that track circuit counting from the feed end to the relay end.

The first negative jumper in the same track circuit will be: AB JN1.

If the cable may be confused with another cable with a similar name, the prefix "TC" may be used in the cable name.

For a jumper connecting the common rail of two track circuits, the cable name should refer to them both (eg AA AB JB1).

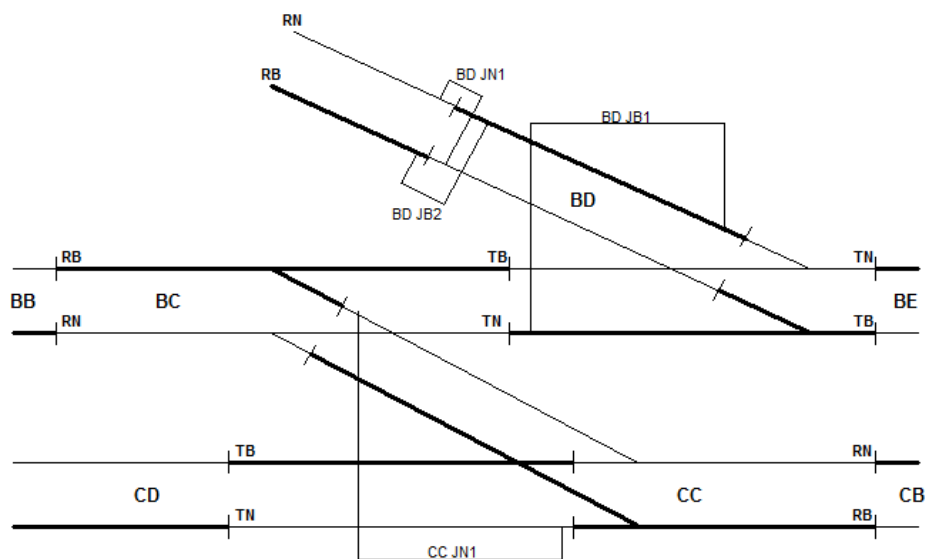

IF REQUIRED, THE PREFIX "TC" MAY BE ADDED BEFORE THE NAMES SHOWN TO MAKE IT MORE OBVIOUS THAT THE CABLE APPLIES TO A TRACK CIRCUIT.  
 THE POSITIVE RAILS ARE SHOWN THICKENED FOR CLARITY IN THIS DIAGRAM ONLY, MOST BONDING & IRJ PLANS WILL SHOW BOTH RAILS AS THE SAME THICKNESS

Figure 13 - Examples of Jumper Cable Identification

## 7 TRACK CIRCUIT INTERRUPTERS

Track circuit interrupters are provided to detect vehicles becoming derailed at open catch or trap points. The interrupter is mounted on the stock rail in the "throw off" direction and as near as possible to the switch toe while maintaining a gap of at least 70mm (2¾") between the interrupter and the switch rail when the switch is closed.

There are two types of interrupter. Older ones are electrically bonded to the rail on one side and to a jumper cable at a suitable point in the track circuit on the other side. When the interrupter is broken, it cuts the feed to the TR. The problem with this arrangement is that it may touch the stock rail to which it would normally be bonded and make up the circuit.

All new interrupters are electrically insulated from the rail on which they are mounted. They are wired within a suitable jumper cable or a feed end cable. The rail on which they are mounted must be of the opposite polarity to the current though the cable. This is so that if a broken interrupter touches the stock rail, it will cause a short circuit and keep the TR down.

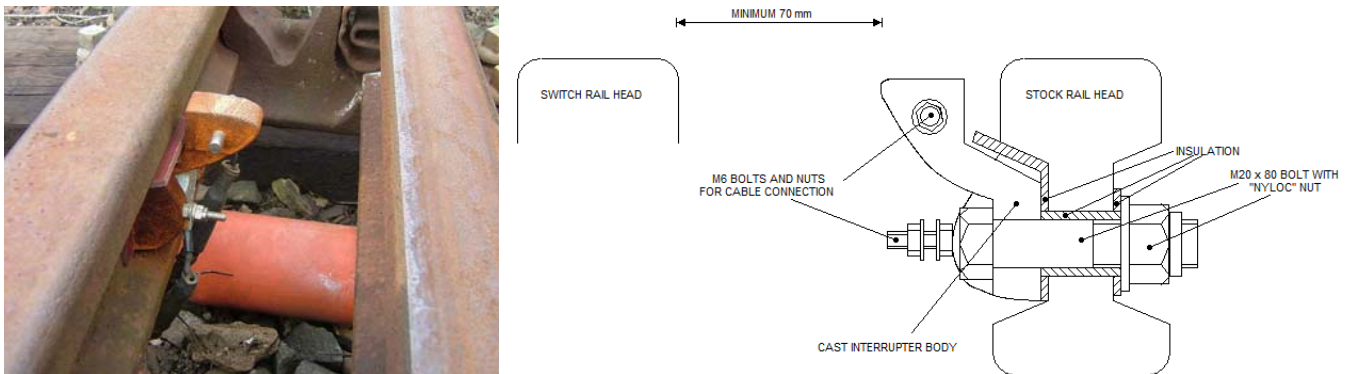

Figure 14 - Track Circuit Interrupter

## 8 TRACK CIRCUIT DESIGN

### 8.1 General

A track circuit should be designed so that as much of the rails as possible are wired in series.

Wiring through points and crossings should be designed with the following consideration;

- Parallel bonding should be kept to a minimum and should not exceed one rail length.
- All IRJs must maintain opposite polarities on either side.
- Opposite polarity must be maintained on each rail as far as possible (see paragraph d below).
- The stagger (displacement) of IRJs on opposite rails must not exceed the requirements of the Railway.
- The total length of the track circuit, including feed, relay and jumper cables, must not exceed the maximum length of the particular track circuit to be used.

Bonding through points and crossings can be either single rail or double rail, depending on the requirements of the Railway. Single rail is normally, but not exclusively, used on electrified lines where one rail is used for traction return.

### 8.2 Plain Line

A plain line double rail track circuit is shown in figure 1. Both rails are electrically isolated from any other track circuit or non track circuit area.

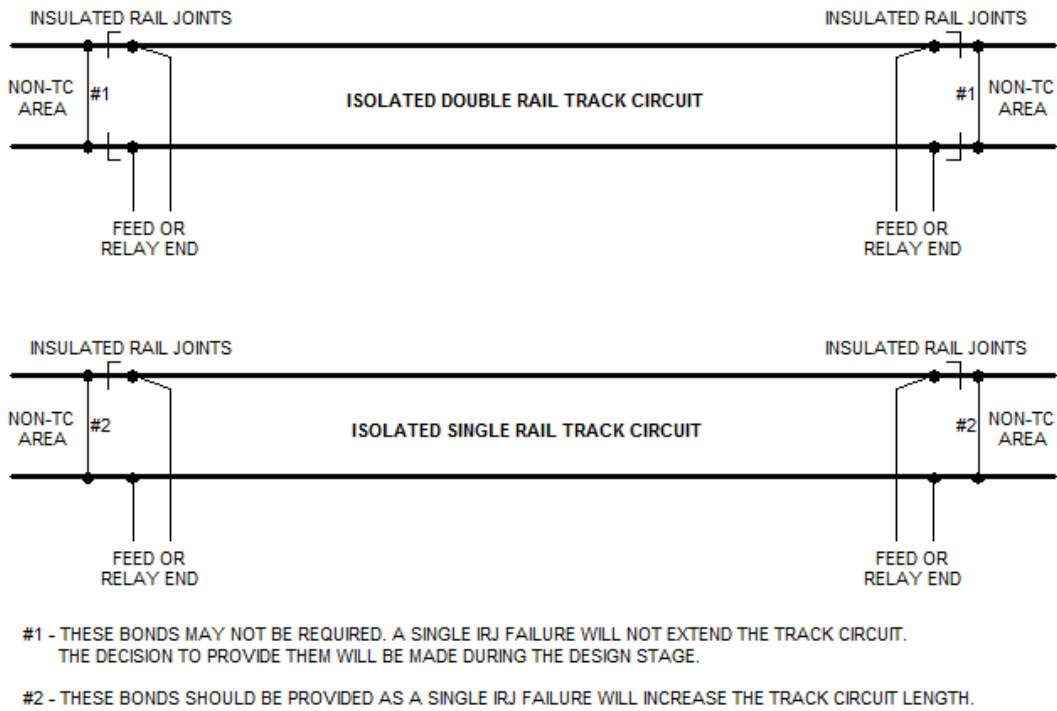

Figure 15 - Typical Plain Line Track Circuits

Installing bonds across the rails on the non-track circuit side of an IRJ will help to detect an IRJ failure, particularly on a single rail track circuit.

### 8.3 Points and Crossings

Bonding through points and crossings should follow as far as practical, the requirements of section 8.1. Double rail track circuits are not generally suitable for use through points and crossings..

It is usually necessary for one or more adjacent track circuit to share one common rail. This is generally the case for a crossover, or more complex S&C, where it is not practicable to fit IRJs opposite each other in the six foot area of the turnout between the running lines.

However, through simple layouts (such as a single point), fully jointed double rail track circuits can be achieved, provided that standard double rail IRJ and bonding arrangements can be applied.

Figures 15 and 16 show typical bonding through points and crossings.

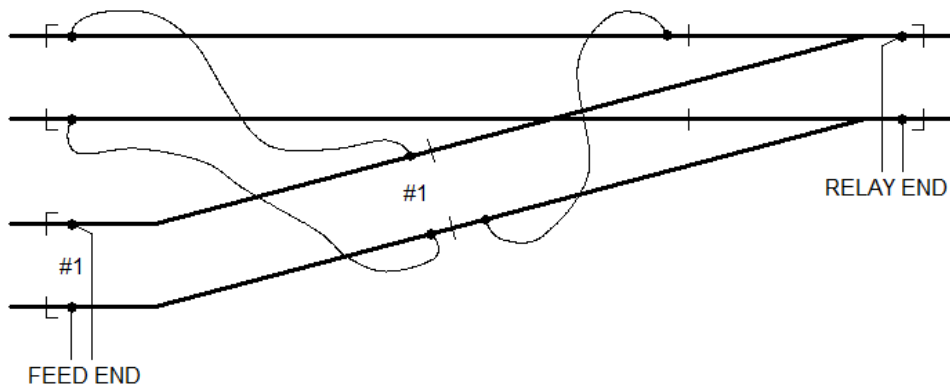

Figure 16 - Typical Bonding for a Single Point

In figure 15, the cable terminations shown as "#1" maybe transposed so as to reduce the jumper cable length.

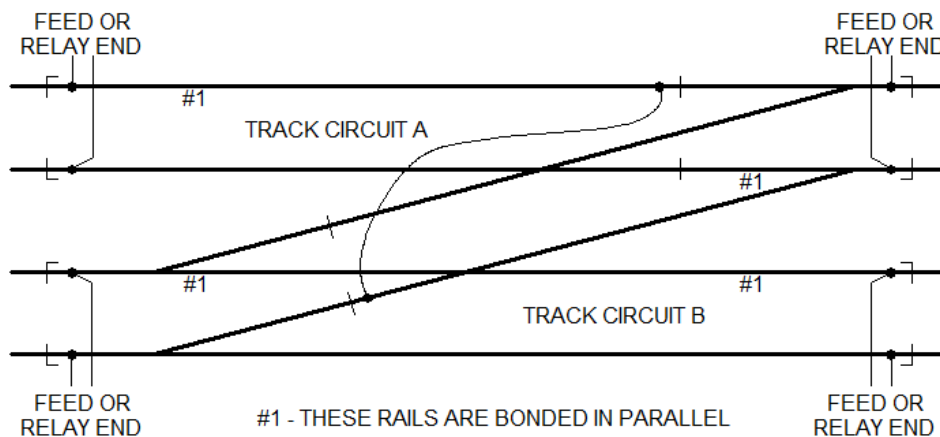

Figure 17 - Typical Bonding for a Crossover

## 9 MAINTENANCE REQUIREMENTS

From October 1<sup>st</sup> 2010 maintenance is subject to the ROGS requirements on minor railways.

### 9.1 Before Starting Work

Before working on any track circuit, inform the signaller and come to an understanding as to the work to be done. Any work which involves disconnecting a track circuit may lock signals and points and prevent train movements.

### 9.2 Details

The track circuit must be maintained so that it is able to detect the presence of trains under all conditions. Therefore all cables and bonds should be intact and maintained with secure terminations.

Cable terminations which are damaged should be re-terminated. Pre-formed cables should be replaced.

Wire bonds which are broken at the rail should be re-terminated if possible. If bonds are broken away from the rail then they should be replaced.

### 9.3 Visual Examination

1. Check all bonding and jumper cables to ensure they are secure and not broken.
2. Check all feed and relay cable terminations on the track and in the location.
3. If provided, check any disconnection boxes are secured with a cover and padlocked.
4. Check that signal wires, point rodding and other metal services are clear of the rails.
5. Check the insulation of all IRJs.
6. Check any insulation of point stretcher bars.
7. Check any track circuit interrupters are secure and are not broken or cracked

### 9.4 Maintenance Standards

Each Railway should establish a maintenance standard, based on the type of equipment used and other prevailing factors listed in section 8.3.

### 9.5 Maintenance Intervals

Track circuit cables and bonding must be inspected at regular intervals. Details of the inspection should be recorded.

The frequency of maintenance will be different for each Railway, based on the following factors, this list is not exhaustive:

- Usage.



- Weather and/or exposure to salt spray or other corrosives.
- Liability to vandalism.
- Operational periods of the railway.

## 9.6 Maintenance Records

It is recommended that every inspection is recorded in a logbook, record card or database.

Generally the following items are recorded:

- Date of inspection
- Who undertook the inspection
- What was replaced

### 9.6.1 Development of Maintenance Plan

The use of the detailed maintenance records will enable the development of a maintenance plan, which will make the best use of the available staff or volunteers.

## 10 REFERENCES

RSSB Railway Group Standards see [www.rgsonline.co.uk](http://www.rgsonline.co.uk)

**RSPGs and RSPs Issued by the Office of Rail Regulation** see [www.rail-reg.gov.uk](http://www.rail-reg.gov.uk)

- [Railway safety principles and guidance Part 1 \(1996\)](#) (HSE 1996)
- [RSPG Part 2B - Guidance on stations \(1996\)](#)
- [RSPG Part 2D - Guidance on signalling \(1996\)](#)
- Railway Safety Publication No 3; [Safe movement of trains](#)
- Railway Safety Publication 4; [Safety critical tasks - Clarification of ROGS regulations requirements](#)
- Railway Safety Publication 5; [Guidance on minor railways](#)

Department for Transport

Railways and Other Guided Transport Systems (Safety) Regulations 2006; Statutory Instrument No 2006/599.

## 11 APPENDICES

None.